



ULTIMA Connect Assembly Method

STAKKAbOX™

ULTIMA Connect



The STAKKAbox™ ULTIMA Connect chamber system features a twinwall sectional design that is made up of GRP corner sections ('hockey sticks') and sidewall lengths. These parts are connected using a jointing peg to form a variety of clear opening sizes. Sidewall lengths used in conjunction with corner sections allows chamber sizes specified by the contractor to be created. Chamber accessories are also available as shown below.

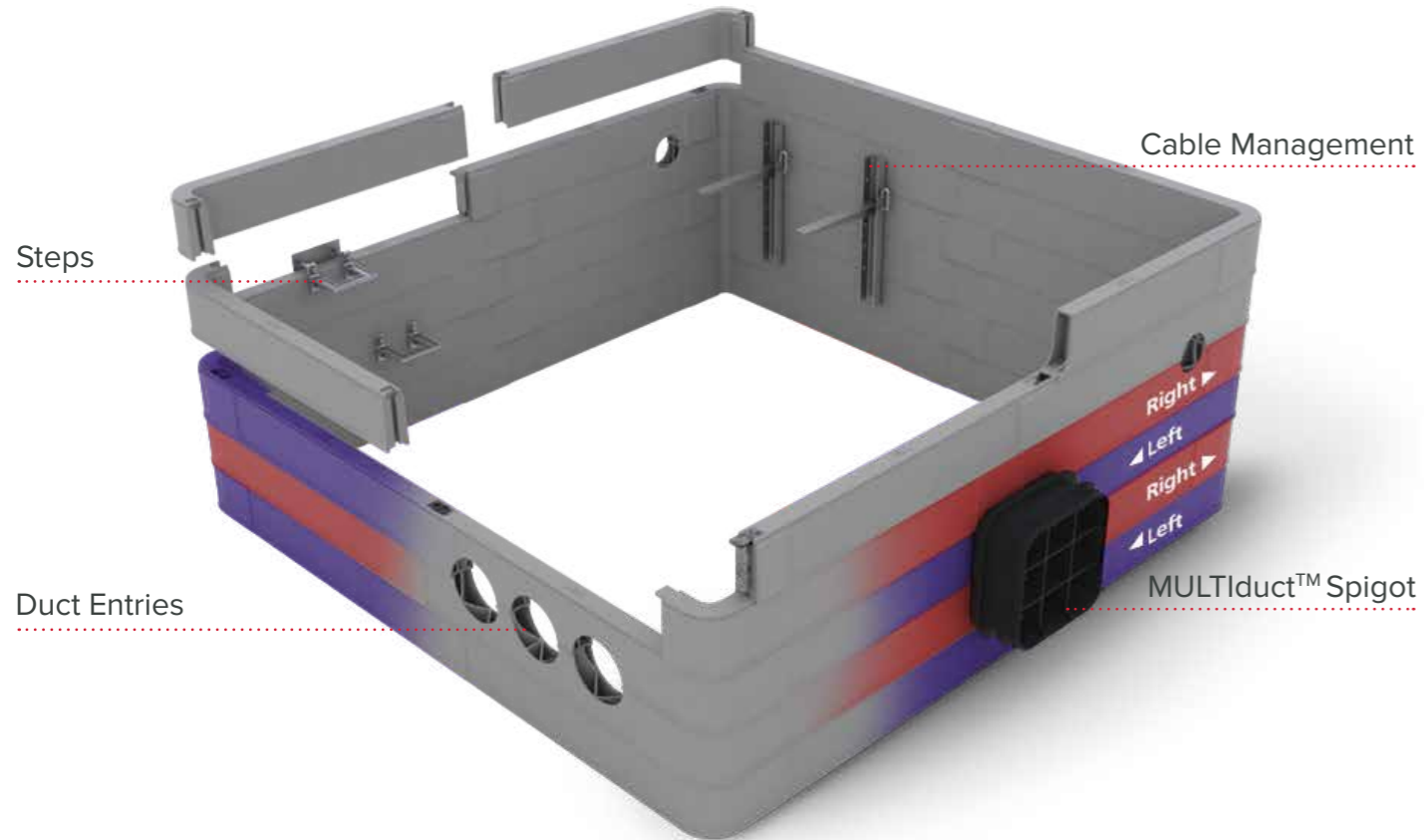

Components (mm)

Corner Sections

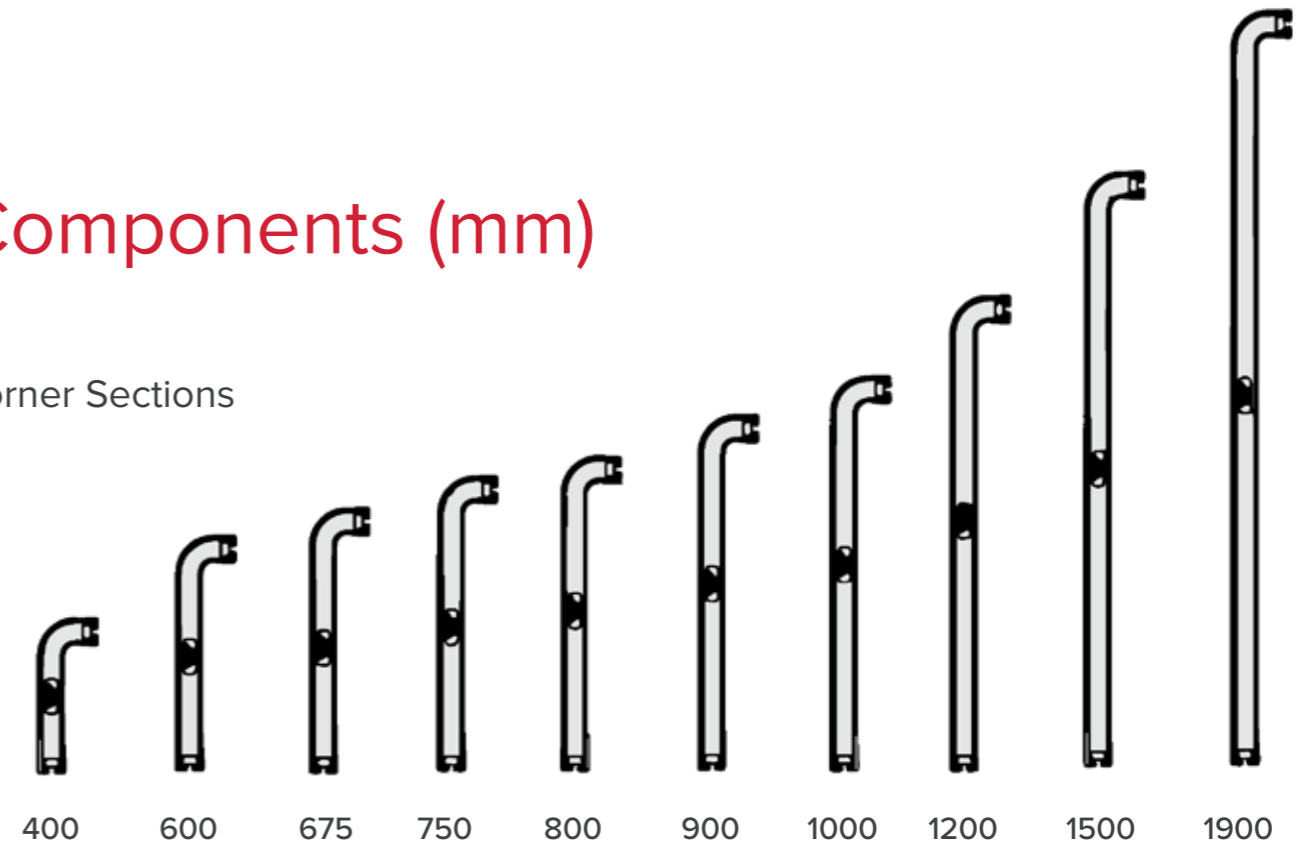

Sidewalls

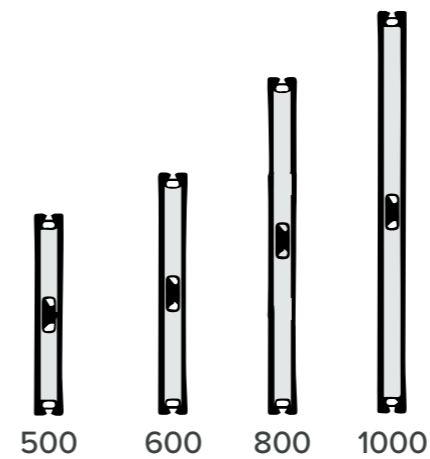

Jointing Pegs

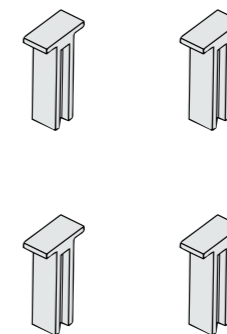

Assembly Method

Using Corner Sections



- 1** a) Arrange corner sections to match the chamber clear opening dimensions. The corner sections should be all 'left' or all 'right' on each section and will alternate between the two as the chamber increases in depth. b) Connect the sections using joining pegs, ensuring that the top of the peg is level with the top of the section. All pegs should be partially inserted before tapping home.

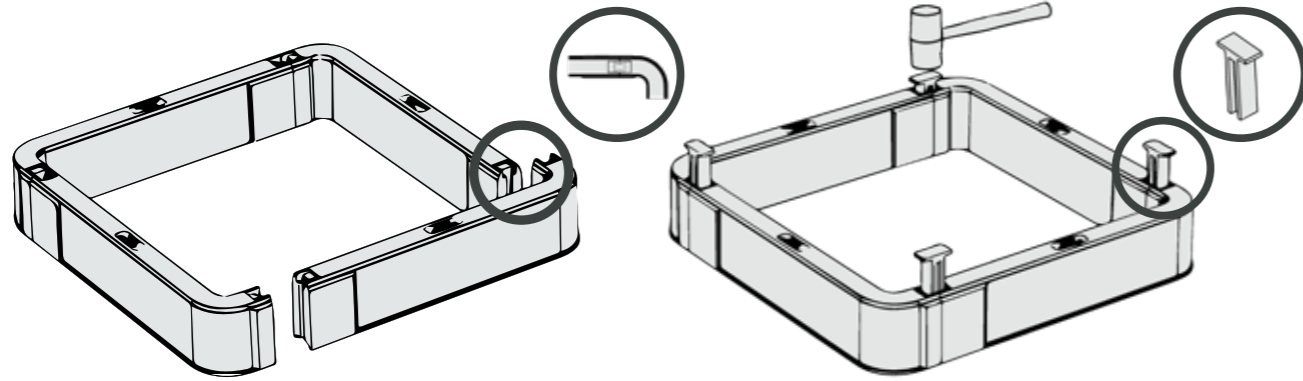

- 2** a) Using the alternative corner section arrangement, lay out the second ring of connect sections to ensure you have the correct components. b) Arrange the component parts sequentially as shown below. This will provide a 'brick worked' chamber ensuring any joints are not in a vertical line.

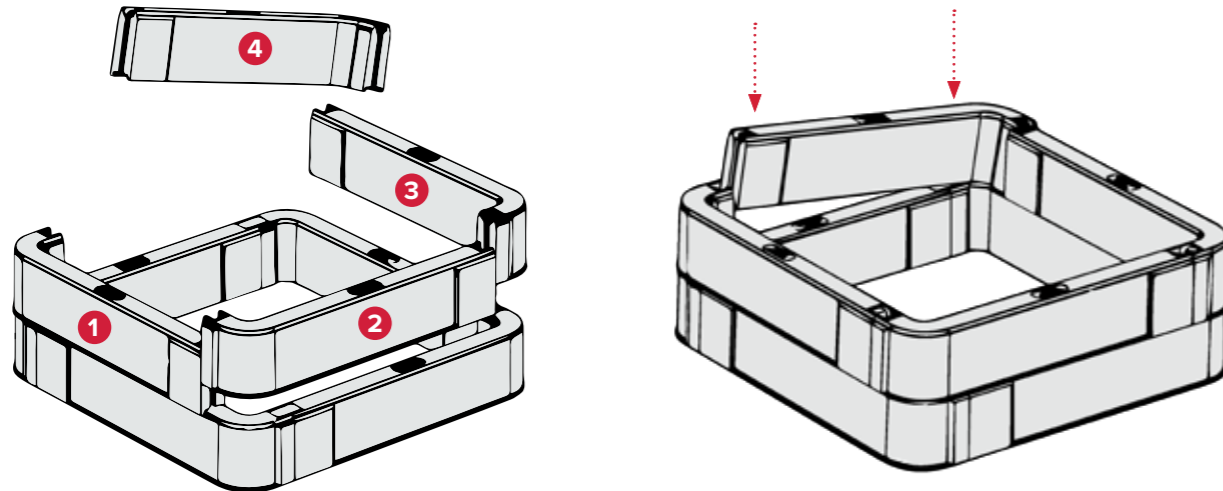

- 3** Connect the sections using joining pegs, ensuring that the top of the peg is level with the top of the section. Repeat steps 1 to 3 until the chamber reaches the specified depth.

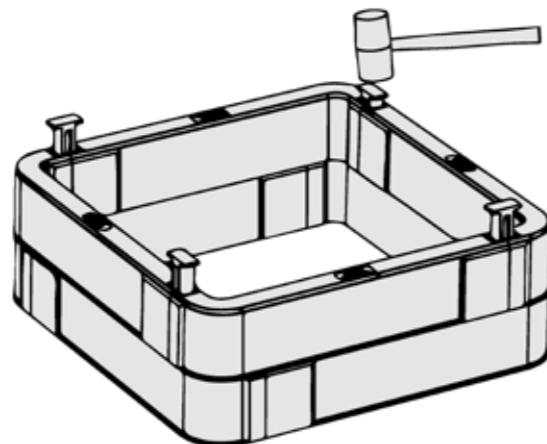

Assembly Method

Using Corner Sections and Straight Lengths

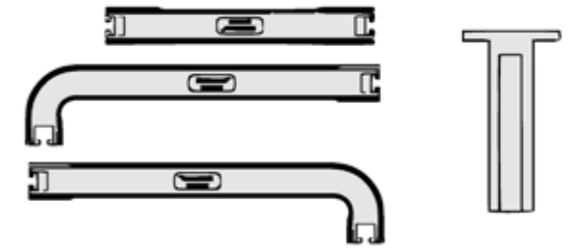

- 1** a) Arrange corner sections and side wall lengths to match the chamber clear opening dimensions. Ensure the lip on the straight lengths are on the outside of the chamber. The corner sections should be all 'left' or all 'right' on each section this will alternate between the two as the chamber increases in depth. b) Connect the sections using joining pegs, ensuring that the top of the peg is level with the top of the section. All pegs should be partially inserted before tapping home.

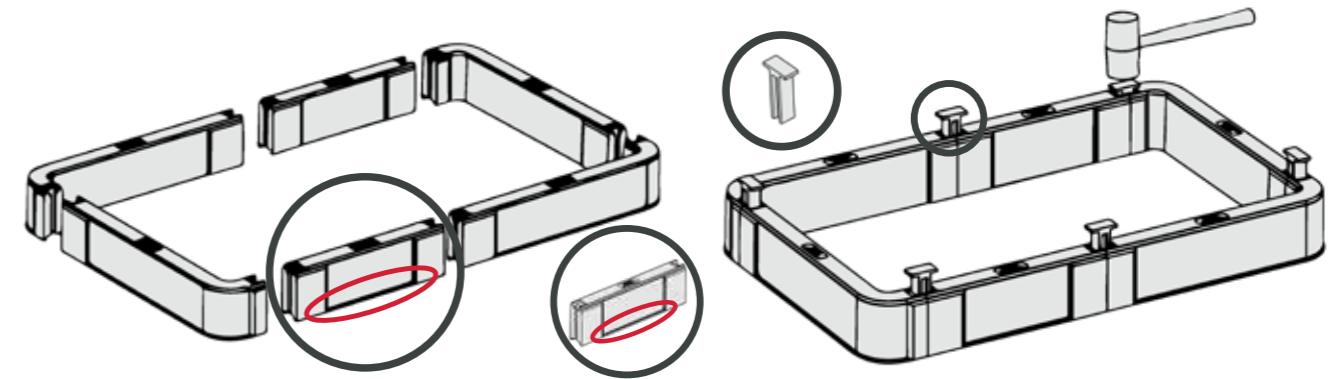

- 2** a) Using the alternative corner sections arrangement, lay out the second ring of connect sections to ensure you have the correct components. b) Arrange the component parts sequentially as shown below. This will provide a 'brick worked' chamber ensuring the joints are not in a vertical line.

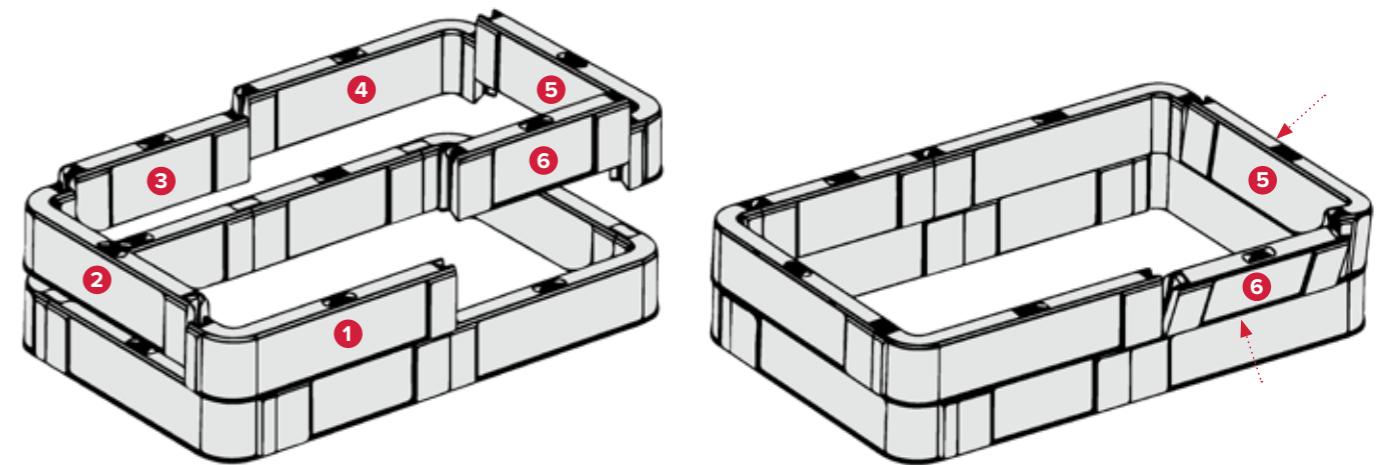

- 3** Connect the sections using the joining peg, ensuring that the top of the peg is level with the top of the section. Repeat steps 1 to 3 until the chamber reaches the specified depth.

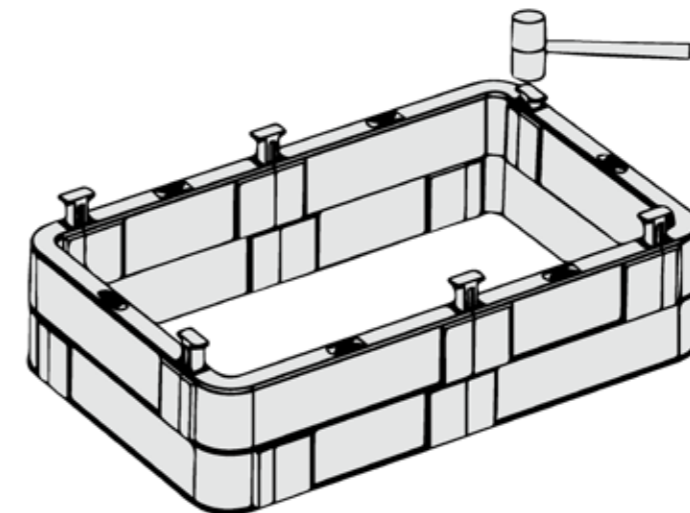

Cubis can also supply colour coded assembly drawings

Contact us:

Head Office:
4 Silverwood Industrial Estate,
Lurgan, Co. Armagh,
BT66 6LN,
Northern Ireland

Telephone: +44 (0)28 38 313 100
Email: info@cubis-systems.com

www.cubis-systems.com



Driven by Innovation

Innovation is the engine that has driven Cubis Systems to its position as global leader in the design and manufacture of access chambers and cable ducting systems.

Inspired by innovation, we have developed quality products that replace traditional construction materials like bricks and concrete. Our lightweight plastics, incorporating intelligent design features, are used in the construction of infrastructure networks for the rail, telecoms, water, construction and power markets worldwide. Cubis products can be installed much faster than traditional methods and therefore save our customers both time and money.

Cubis manufactures the preformed STAKKAbox™ network access chamber systems, the AX-S™ access covers range, a MULTIduct™ multiple duct system and the PROtrough cable troughing system at sites throughout the UK and Ireland. These innovative products are exported to more than 25 countries throughout the world.

At Cubis we are committed to ongoing innovation and dedicated to delivering absolute product quality, detailed technical customer support and the highest levels of customer satisfaction.